

## Features

- Woofer, Microspeakers, Headphones
- Systems (sealed, vented enclosures)
- On-line transducer parameter measurement
- Offset of voice coil rest position
- High-speed temperature monitoring
- Voice coil displacement with and without laser
- Monitors destruction process
- User defined failure limits
- Monitoring 8 DUTs simultaneously
- Stand-alone operation
- Driver status displayed on hardware
- Analysis of recorded measurement
- Internal and external stimuli
- Stimulus shaping/filtering
- Voltage Control at terminals
- Voltage stepping, ON/OFF Cycling

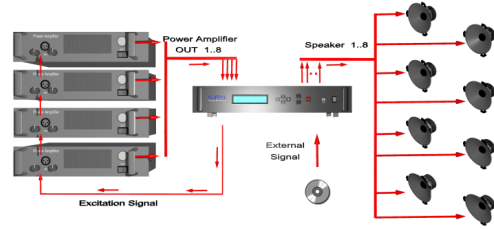

The software module PWT performs on-line monitoring and power testing of transducers, active and passive loudspeaker systems and power amplifier using the hardware platform Distortion Analyzer or Power Monitor 8 (8 channels). An internal generator provides a variety of test stimulus (sweep, tone, noise) according standards and flexibility for generating special stimuli with user-defined bandwidth, crest factor. The PWT also supports external stimuli such as music to perform in-situ measurements which simulate the final application of the test object. The amplitude of the stimulus may be automatically controlled using predefined amplitude profile (gain stepping, on/off cycling). The PWT is based on voltage and current measurements and derives the voice coil temperature from the electrical impedance at a user defined frequency of a pilot tone added to the stimulus. The PWT also monitors the small signal and large signal parameters according IEC standard 62458.

Article Number: 1000-700(PM8+DA2), 1000-710(PM8+DA2), 1000-720(PM8)

## CONTENTS:

Measurement Technique.....	2
Basic Hardware Setup .....	3
Temperature Measurements .....	4
Stimulus .....	7
Transducer Identification.....	8
Sampling and Recording.....	10
PC based Operation .....	11
Limits .....	13
Transducer .....	13
External Excitation .....	13
Power Amplifier.....	13
Automatic Pilot Tone Adjustment.....	13
Manual Pilot Tone Adjustment.....	14
Input Parameters (Setup).....	14
Measurement Results.....	16
Example: Analysis of the Destruction Process.....	17
Patents.....	18

updated 30 March 2017

## Measurement Technique

### Principle

The PWT measures voltage and current at the terminals of the device under test and identifies voice coil resistance, temperature and other small and large signal parameters of the transducer. The devices under test (DUT) are excited by a stimulus generated by internal generator or provided by an external source. The external and internal test signals can be controlled by a user defined amplitude profile (gain stepping) or ON/OFF cycling. A pilot tone is added to the stimulus and is the basis for measuring the electrical input impedance at a user-defined frequency (2Hz ...20 kHz) and for calculating the voice coil temperature accurately. This technique can cope with an AC-coupled power amplifier, active and passive crossovers and stays operative when the stimulus is muted. The hardware platform (DA2 or PM8) provides not only sensitive voltage and current sensors (hall sensors) with low series resistance (< 0.01 Ohm) but also an emergency switch which disconnects the drive if the DUT is defective.

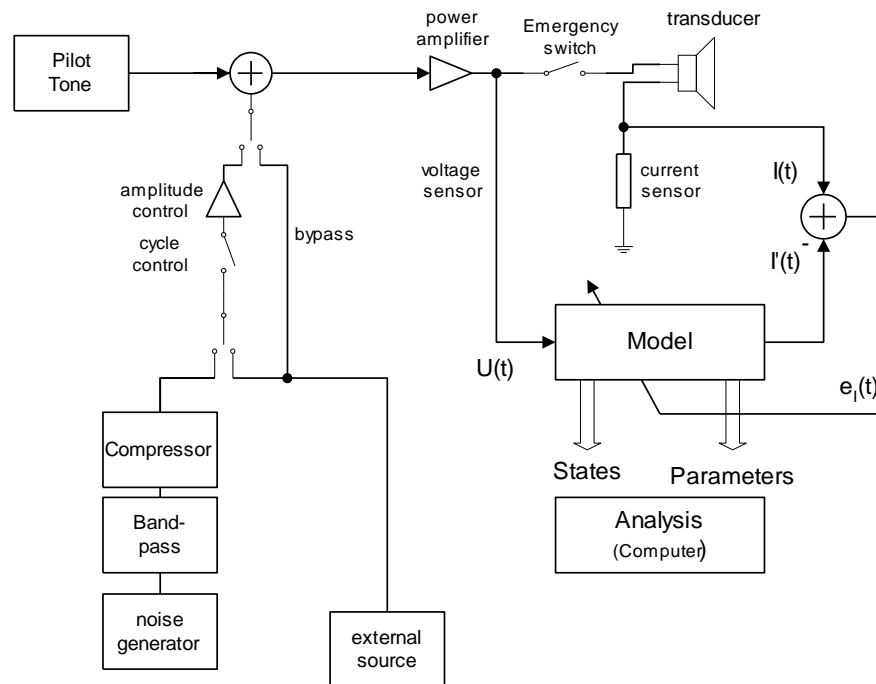

The sampled data are stored in a history buffer within the stand-alone hardware. Connecting a computer via USB to the hardware device enables viewing the history of the measurement and failure diagnostics.

There are two modes of system identification:

1. In the mode **TEMPERATURE** the voice coil temperature  $T_v$  and the electrical quantities (peak and rms voltage and current, real input power) are permanently monitored. This mode can be applied to woofers, tweeters, and passive and active loudspeaker systems and power amplifiers.
2. In the mode **TRANSDUCER IDENTIFICATION** the electrical and mechanical parameters of woofers in free air, vented or sealed enclosure, microspeakers, headphone transducers are identified on-line. The transducer should correspond with the large signal model presented below.

## Basic Hardware Setup

### Internal Mode

The Power Test Software operated in the *Internal* mode requires minimal components:

- Power Monitor 8 (or Distortion Analyzer)
- Power amplifier(s)
- Amplifier cables
- Speaker cables

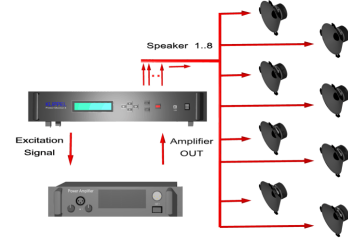

The stimulus (noise, sweep, test tones) is generated internally and supplied at the output XLR connector OUT1. The internal mode controls the amplitude of the stimulus automatically, performs an ON/OFF cycling and a stepping functionality. The Internal Mode is optimal for testing multiple units of the same type using the same stimulus to ensure statistical confidence.

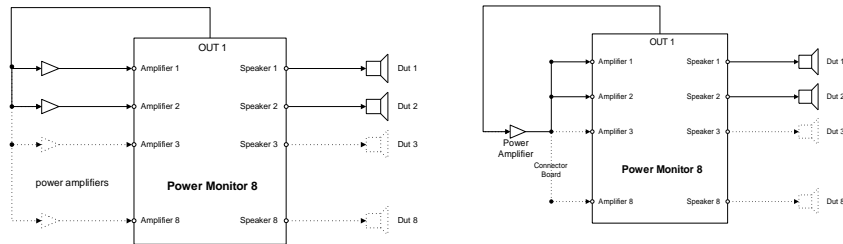

Use a separate amplifier for each DUT if the impedance of the transducers is relatively low and the power amplifier may not provide the current for multiple DUTs connected in parallel.

A powerful amplifier may be used for driving multiple DUTs such as micro-speakers, headphones connected in parallel.

### External Mode

The external mode uses an external signal generator providing a continuous stimulus such as noise or other test signals to the input IN1 of the power test platform (DA2 or PM8). After ON/OFF cycling and adding the internal pilot tone the stimulus is supplied at the user-defined amplitude with a desired profile (amplitude stepping) controlling the amplitude at OUT 1 connected to the power amplifier(s). Thus the gain of the power amplifier is automatically compensated. The External mode is optimal for testing multiple units of the same type like the internal mode.

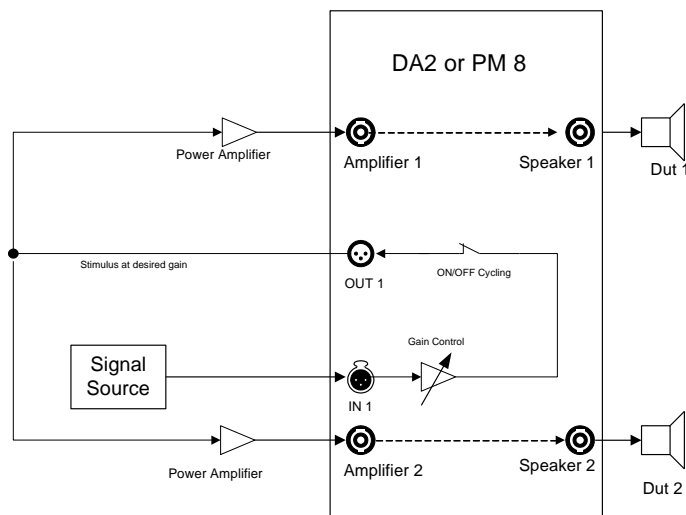

**Bypass Mode**

The Bypass mode can be applied to any external stimulus such as music, test signals. Contrary to the Internal and External Mode it is not required to feed the stimulus via IN1 and OUT1 through the DA2 or PM8 hardware before it is supplied to the power amplifier. There is no gain control of the stimulus to the desired target voltage at the speaker terminals. The user can modify the amplitude of the stimulus manually by changing the gain of the generator or power amplifier.

The Bypass mode is perfect for in-situ monitoring of the loudspeaker in the final application. It is also very flexible for testing different types of loudspeakers at the same time using a different stimulus for each unit.

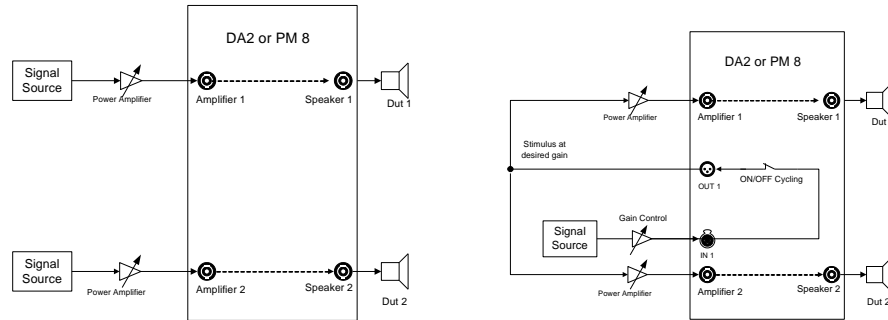

The Bypass mode allows using separate signal sources for each device under test. The voltage at the terminals is controlled manually by changing the gain at the power amplifier until the monitored voltage at speaker terminals fit the target value.

Alternatively, the stimulus from the external signal source may be transferred via IN1 and OUT 1 through the power test hardware to realized ON-OFF cycling in the bypass mode. The PWT software displays the monitored voltage at the loudspeaker terminals and the user adjusts the gain at the signal source or power amplifier to realize the desired target voltage.

**Temperature Measurements**

**Reference Resistance**

The voice coil temperature is calculated by comparing the dc resistance  $R_e(t)$  corresponding with the absolute voice coil temperature  $T_v(t)$  at measurement time  $t$  with a reference resistance  $R_{ref}$  measured at the reference temperature  $T(t_{ref})$ . The reference temperature corresponds with the ambient temperature when the driver is in thermal equilibrium either at the beginning of the power test or during a long OFF-Cycle. The electrical dc resistance can be estimated by measuring the electrical impedance  $Z_e(f_p)$  at a very low frequency ( $f_p=2$  Hz is recommended for woofers) or at other frequency where the impedance is minimal (recommended for loudspeaker systems with crossover).

**Increase of Voice Coil Temperature**

The increase of the voice coil temperature during the power test expressed in Kelvin

$$\Delta T_v(t) = \frac{1}{\delta} \left( \frac{R_e(\Delta T_v(t) + T_v(t_0))}{R_e(T_v(t_0))} - 1 \right) \approx \frac{1}{\delta} \left( \frac{Z_e(f_p, \Delta T_v(t) + T_v(t_0))}{Z_e(f_p, T_v(t_0))} - 1 \right)$$

is calculated by using the cold resistance  $R_{ref}=R_e(t_0)$  at starting time  $t=t_0$  as reference and the thermal conductivity coefficient  $\delta$  for the voice coil material.

**Why adding a pilot tone?**

The measurement of voice coil temperature is based on assessing the electrical input impedance at specified frequency. This method requires voltage and current monitoring only. The DC resistance measured at the loudspeaker terminals by a 4-wire cable (There is no current in two wires used for voltage measurement) is the most accurate way for estimating the voice coil temperature. However, using a low frequency tone  $f_p$  ( 2Hz ... 8 Hz) is more convenient than a DC stimulus because an AC signal can pass the high-pass of the power amplifier. Loudspeaker systems with integrated amplifiers or active or passive crossovers require a pilot tone at higher frequencies. Setting the pilot tone in the minimum of the impedance curve gives a temperature estimate which is less accurate than monitoring the resistance at low frequencies close to dc. In both cases the ac pilot tone keeps the temperature measurement operative while the external stimulus is muted.

Measurement of the voice coil temperature without pilot tone in is not recommended! If the stimulus does not provide enough spectral energy at the selected frequency where the electrical impedance is measured the temperature will be inaccurate.

**Temporal resolution**

The time constants affecting the temperature measurement are also adjustable during measurement. The mode **Fast** is recommended for monitoring of fast thermal transients produced by tweeter systems. The mode **Slow** recommended for woofer application.

**Automatic Pilot Tone Adjustment**

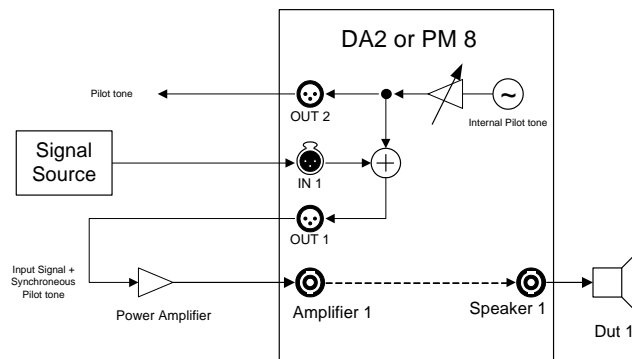

If the checkbox AUTOMATIC PILOT TONE is activated the pilot tone is set to the lowest frequency (2,4,8 Hz) which passes the amplifier’s high-pass at sufficient amplitude. The amplitude of the pilot tone is controlled automatically to generate an optimal pilot tone at the speaker terminals. This mode is convenient for testing drive units without crossover.

**Manual Pilot Tone Adjustment**

The automatic adjustment may be disabled and the user may specify the frequency and the voltage at the output XLR connectors OUT1 and OUT2 at DA2 or PM8 of the pilot tone for each DUT manually. While the pilot tone used in the TEMPERATURE Mode can be set to any audio frequency (2... 20 kHz) the TRANSDUCER IDENTIFICATION requires a low frequency tone (2,4 or 8 Hz) close to dc.

Application: Simultaneous measurement of woofers ( $f_p= 2$  Hz) and tweeters ( $f_p= 1$ kHz).

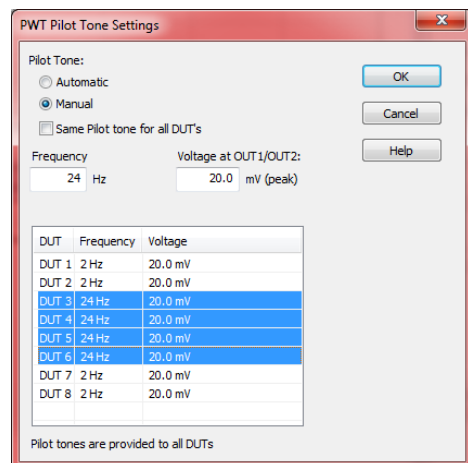

**Internal mixing of user-defined Pilot Tone**

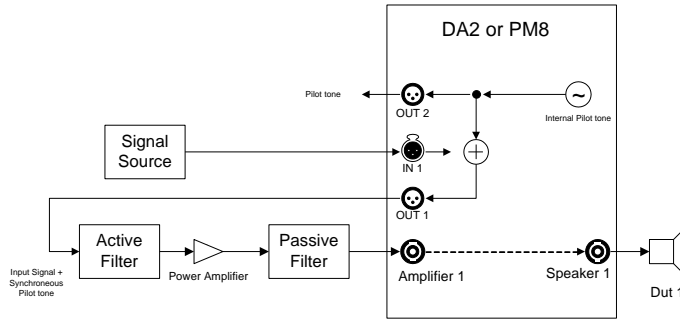

The figure above shows a first application of the manual pilot tone adjustment which is applicable to INTERNAL, BYPASS and EXTERNAL Modes. The user defines the frequency (2Hz ... 18 kHz) and the fixed amplitude of the pilot tone at XLR connector OUT1 which is superimposed with the internal or external power test signal. Using a fixed pilot tone speeds up the initial phase of the power test. This setup is convenient for power testing of drive units together with the active or passive crossover.

**External mixing of User-defined Internal Pilot Tone**

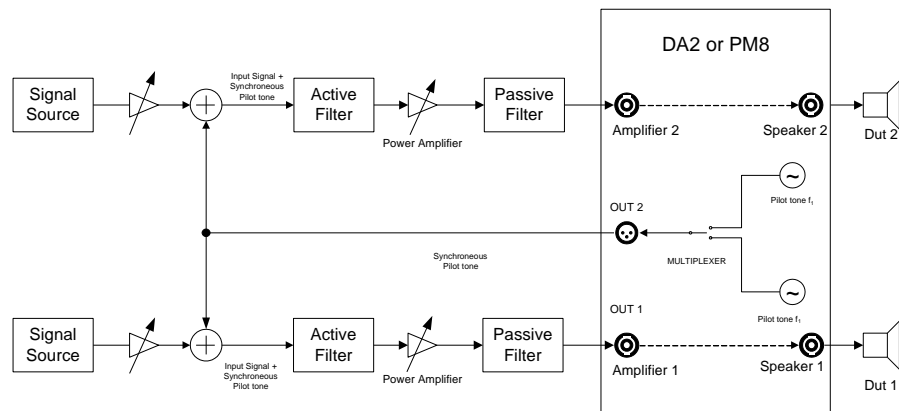

The application in the figure above performs an external mixing of the pilot tone provided at OUT2 of the measurement system with the external power test stimulus before feeding this signal via power amplifier and electrical monitoring to the terminals of the transducer. This setup requires the BYPASS mode and MANUAL PILOT TONE ADJUSTMENT because the stimulus can only be controlled by the gain controllers at the signal source or in the power amplifier. The user defines the frequency (2Hz ... 18 kHz) and the fixed amplitude of the pilot tone according to the impedance minimum of the transducer and the gain of the power amplifier.

This setup is convenient for power testing of different types of drive units requiring a special pilot tone frequency for each drive unit and using the special power test signals coming from different sources. The pilot tone at OUT 2 is multiplexed after 1s intervals according to the instantaneous device monitored.

**User-defined External Pilot Tone**

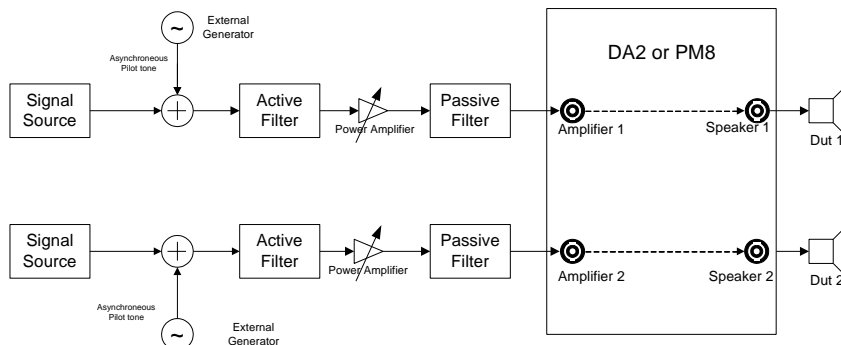

	<p>This application shown above uses only external signal sources for power testing. If the stimulus does not provide sufficient spectral density at the frequency <math>f_p</math> specified in the PP MANUAL PILOT TONE then it is recommended to add a separate pilot tone at the same frequency <math>f_p</math> which is asynchronous to the analysis performed in the hardware.</p> <p>The manual adjustment of the pilot tone on the PP Method allows an adjustment of the expected frequency of the asynchronous pilot tone generated by an external signal source (generator, wave file). The permissible frequency mismatch should be smaller than <math>\Delta f &lt; 1</math> Hz for a pilot frequency <math>f_{\text{pilot}} &lt; 8</math> Hz and <math>\Delta f &lt; 4</math> Hz for a pilot frequency <math>f_{\text{pilot}} &gt; 8</math> Hz.</p> <p>Application: Avoiding the feedback of the pilot tone from OUT1 (stimulus + pilot tone) or OUT2 (pilot tone only) to the amplifier.</p>
<b>Detailed Temperature Response</b>	<p>If Number of DUTs is equal 1 then the results window Temperature Detail shows the voice coil temperature at high temporal resolution (sampled at 200 ms). The detailed temperature measurement may be started automatically or manually and synchronized with the cycling (at the OFF/ON and ON/OFF slope). Detailed curves may be collected in the result window <i>Temperature</i> by using <i>copy and paste curve</i>.</p>
<b>Fast Temperature Measurement</b>	<p>The PWT software supports temperature measurement at high temporal resolution (200ms sampling time) which is important for micro-speakers and headphones having a small thermal time constant of the voice coil. The following factors are important:</p> <ul style="list-style-type: none"> <li>• Use a short integration time by selecting “FAST” speed on PP <i>Method</i></li> <li>• Use manual pilot tone adjustment and set the pilot tone frequency <math>f_p \geq 8</math> Hz for monitoring micro-speakers, tweeters having a resonance frequency <math>f_s &gt; 100</math> Hz. Note: Subwoofers and woofers need a lower frequency of the pilot tone (<math>f_p &lt; f_s/10</math>) to suppress the influence of the motional part of the electrical impedance (automatic pilot tone adjustment or manual setting to <math>f_p = 2</math> Hz is recommended for subwoofers)</li> </ul>

<b>Stimulus</b>	
<b>Excitation Source</b>	The stimulus used during Power Test may be provided by an external source (CD-player, generator) or from the internal noise generator.
<b>Internal Signal Generator</b>	The measurement hardware hosts an internal generator producing a test signal such as noise with pink or white spectral characteristic, sinusoidal sweep or a two-tone signal.
<b>Stimulus Shaping</b>	The internal excitation signal may be preconditioned to have user-defined signal properties (crest factor and bandwidth).
<b>Cycle Control</b>	The stimulus may be switched on and off during Power Test to simulate variations of the voice coil temperature. The user may define the cycles or the time scheme.
<b>Amplitude Control</b>	The voltage $U(t)$ at the terminals may be set to a user-defined RMS-value while considering the amplitude gain of the power amplifier and the amplitude of the stimulus. This value may be constant during the measurement or increased automatically by user-defined steps.

## Transducer Identification

### Large Signal Model

The TRANSDUCER IDENTIFICATION can be applied to any electro-dynamical transducer using a moving coil which can be described by the lumped-parameter model

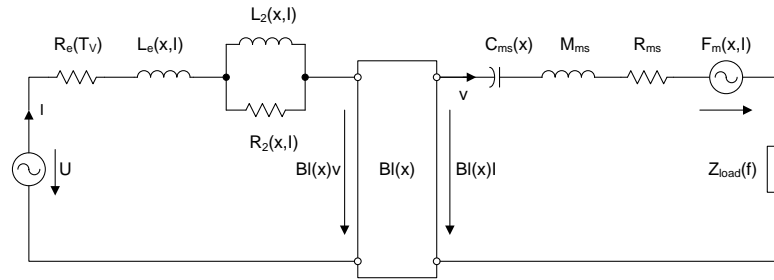

using the nonlinear elements

- Electro-dynamical force factor  $BI(x)$  versus displacement
- Compliance of mechanical suspension  $C_{ms}(x)$  versus displacement
- Voice coil inductance represented by  $L_e(x,I)$ ,  $L_2(x,I)$  and  $R_2(x,I)$  versus displacement  $x$  and current  $i$
- Voice coil resistance  $R_e(T_v)$  versus temperature  $T_v$
- total moving mass  $M_{ms}$  considering air mass
- mechanical resistance  $R_{ms}$  considering all mechanical and acoustical losses
- the mechanical load  $Z_{load}(f)$  representing an additional 2<sup>nd</sup> order mechanical or acoustical resonator (vented box) coupled to the woofer.

An additional passive components used as crossover (capacitors) are not considered in the modeling and may affect the accuracy of the identified parameters.

The following transducer and audio systems may be selected:

- Woofer in free air or in sealed enclosure (2<sup>nd</sup> order system with  $f_s < 500$  Hz)
- Woofer in vented enclosure or with additional 2<sup>nd</sup>-order resonator (4<sup>th</sup> order system with  $f_s < 200$  Hz)
- Micro-speaker or headphone transducer with negligible inductance (2<sup>nd</sup> order system with  $f_s < 900$  Hz)

### Persistent Excitation

The TRANSDUCER IDENTIFICATION requires a stimulus which provides sufficient amplitude at the frequency components close to the fundamental resonance. Music and test signals such as noise signal or multi-tone complex having at least one-decade bandwidth are good stimuli. A sinusoidal sweep is less optimal for the identification because there is no intermodulation distortion generated. A single tone at fixed frequency gives not sufficient information for the full identification of a transducer. The PWT generates a warning "No persistent Excitation" if the identification fails due to the properties of the external stimulus.

### Monitored Signals

The TRANSDUCER IDENTIFICATION is based on voltage and current measured at the terminals of the transducer by using a four-wire technique. Optionally the voice coil displacement of one DUT can be measured by using a laser triangulation sensor connected to DA2. The laser signal is not used for the transducer identification but the peak, bottom and mean DC displacement are displayed in the result window displacement and can be compared with the displacement predicted by the transducer model.



<b>Initial Identification</b>	<p>Before starting with the regular power testing an initial identification of the driver parameters is performed using an optimal internal stimulus providing persistent excitation of the transducer. Similar to the procedure in the Large Signal Identification (LSI) the following steps are performed:</p> <ol style="list-style-type: none"> <li>1. Amplifier check (cables, gain control)</li> <li>2. Measurement of the cold voice coil resistance</li> <li>3. Identification of small signal parameters</li> <li>4. Identification of the nonlinear parameters</li> <li>5. Start of the power test using external stimuli, on/off cycling, ...</li> </ol>
<b>On-line monitoring</b>	<p>During the following on-line mode (regular power test with user defined stimulus) the following time varying parameters are permanently updated:</p> <ul style="list-style-type: none"> <li>• Voice coil DC resistance <math>R_e(t)</math></li> <li>• Stiffness of the mechanical suspension <math>K_{ms}(x=0, t)</math> at the rest position <math>x=0</math></li> <li>• Resistance <math>R_{ms}(t, x=0)</math> representing the mechanical losses</li> <li>• Offset <math>x_{off}(t)</math> in the voice coil rest position changes the working point in the displacement varying parameters stiffness <math>K_{ms}(x+x_{off})</math>, force factor <math>Bl(x+x_{off})</math> and inductance <math>L(x+x_{off})</math></li> </ul> <p>Note: The relative shape of the nonlinear parameters as identified during the initial identification is not updated during the on-line monitoring to cope with test signals which provide no persistent excitation of the transducer.</p>
<b>Mechanical Parameters</b>	<p>The TRANSDUCER IDENTIFICATION is based on an electrical measurement but the back EMF also provides essential information on the mechanical system such as</p> <ul style="list-style-type: none"> <li>• resonance frequency <math>f_s(x=0)</math> and Q factors at the rest position <math>x=0</math></li> <li>• relative displacement <math>x/x_{peak}</math></li> <li>• shape of the mechanical stiffness curve <math>K_{ms}(x/x_{peak})/K_{ms}(x=0)</math></li> </ul> <p>The relative mechanical parameters and states can be transformed into absolute mechanical data such</p> <ul style="list-style-type: none"> <li>• voice coil displacement in mm</li> <li>• stiffness <math>K_{ms}(x)</math> in N/mm versus displacement in mm</li> <li>• force factor <math>Bl(x)</math> in N/A</li> </ul> <p>by importing a mechanical calibration parameter such as the force factor <math>Bl(x=0)</math> at the rest position or the moving mass <math>M_{ms}</math>. No additional mechanical sensor (e.g. laser) is required.</p>
<b>Measurement of T/S parameters in a noisy environment</b>	<p>The TRANSDUCER IDENTIFICATION describes the loudspeaker in the small and in the large signal domain. However, the stiffness value <math>K_{ms}(x=0)</math> at the rest position <math>x=0</math> depends on the peak displacement <math>x_{peak}</math> generated by the stimulus due to the visco-elastic behavior of the suspension (creep effect). Thus the Thiele-Small parameters defined in the small signal domain are slightly different from the parameters measured in the large signal domain.</p> <p>Accurate small signal measurements of the T/S parameters may be performed by using the R&amp;D module Linear Parameters Measurements (LPM) at small amplitudes which is interlaced with the PWT performing the power test at high amplitudes using the concept of the intermittent testing (see below in section PC operation).</p>

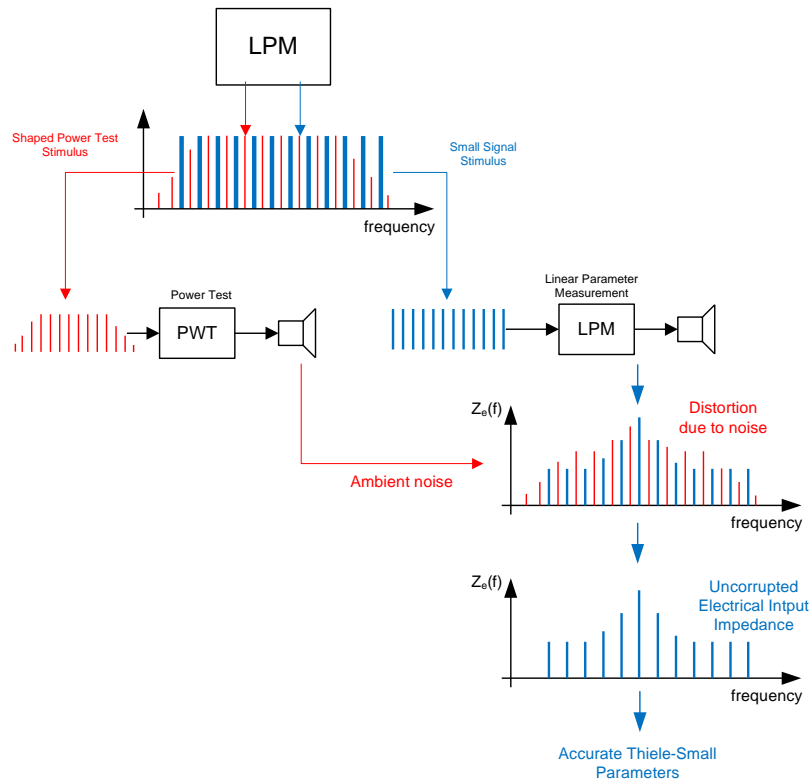

However, a small signal measurement may be corrupted by noise generated by other DUTs tested at full power in a relatively small power test room or climate chamber. The figure above illustrates a technique how to cope with the “microphone effect” by using a power test stimulus in PWT which is incoherent with the small signal stimulus used in the LPM. Those stimuli are two sparse multi-tone complexes using excitation tones placed at different frequencies. The LPM may be used for generating incoherent stimuli with a custom-defined spectral shaping which may be exported as a wave-file to the LPM and PWT measurements.

### Sampling and Recording

**Regular Sampling** During the Power Test all of the parameter estimates and important characteristics of the state variables (peak and RMS values) are sampled periodically and stored in a history buffer within the hardware. Connecting a computer via USB interface makes it possible to upload, view and save the history of the measurement and to investigate temporal variations of the parameters due to thermal, reversible and irreversible processes. The user may define the time elapsing between taking samples (regular sample period).

**Status Information** During the Power Test the status of the DUT may be viewed in detail by the software module Power Test hosted by the dB-Lab frame software. Additionally, the most important information is directly shown on the display at the hardware device:

- Number of DUTs connected
- Status of the DUTs (alive, malfunction)
- Malfunction of the amplifier
- state variables (peak displacement, temperature, input power, RMS voltage)

**Malfunction Detection** Several malfunctions of the driver will be detected by Power Test Software automatically. On the property page FAILURE the user may specify a permissible variation of the dc resistance  $R_e$  to detect a short-cut or an open connection.

**Disconnect** In the case of an electrical shortcut between the driver terminals the Power Test Software (PWT) will disconnect the defect unit from the power amplifier automatically.

<b>Defect Unit</b>	The user may disable this feature and keeps the monitoring of the defect driver active. This mode is convenient for replacing units while the power test is active but requires special caution to avoid fire hazards.
<b>Death Report</b>	In addition to the regular sampling all values are measured internally at a much higher rate and stored in a ring buffer of the hardware. In case of an identified malfunction this high sampled data of the particular DUT are copied into the history data buffer. This allows a detailed analysis of the time just before destruction. This information is important to find the cause of the failure.

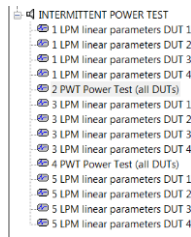
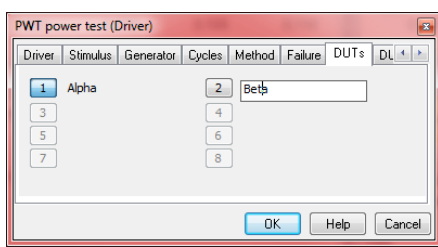
<b>PC based Operation</b>	
<b>USB connection</b>	The universal serial bus (USB) makes it easy to connect or disconnect a computer with a processor unit (PM 8 or DA 2) without interference with a running measurement. Using hubs multiple units may be connected to one PC. The software tool SPY shows the display of each hardware unit on the PC.
<b>Database</b>	Connecting a PC via USB to the monitoring hardware (Distortion Analyzer 2 or Power Monitor 8) all of the sampled data will be stored in a database for detailed analysis and diagnostics.
<b>Customizing Setup</b>	The property pages of PWT give access to a variety of setup parameters which may be used to customize the Power Test. The setup parameters may be stored in the hardware device and may be activated by starting the hardware in stand-alone operation.
<b>Import Parameter</b>	The system identification is based on an impedance measurement providing electrical parameters and states in absolute quantities (Volt, Ampere, Watt) but the mechanical system as relative quantities only. Importing one mechanical parameter (moving mass $M_{ms}$ or $Bl(x=0)$ at the rest position) allows to calibrate all state variables (e.g. displacement in mm) and all of the mechanical parameters (e.g. compliance in mm/N).
<b>Intermittent Testing</b>	<p>The KLIPPEL PC frame software dB-Lab provides the BATCH PROCESSING of all operations (PWT, LSI, LPM, TRF) belonging to a test object. Multiple PWTs interlaced with Linear Parameter Measurements (LPM) are processed sequentially providing the Thiele-Small parameter before, after and at defined time during the power test.</p> 
<b>Name of DUTs</b>	<p>To simplify the handling of multiple units measured at the same time the property page DUT allows to assign a name to each DUT to identify the measurement results of a particular DUT which may be stored in multiple PWT operations. The Comment file INFO may also be used to store additional information about the devices under test.</p> 

**Replacing DUTs**

Power test performed at multiple units of the same type required statistical analysis are usually started and finished at the same time. However, the PWT software also supports measurements of different loudspeaker types started at arbitrary times by the following steps:

1. Finish the old PWT, remove the DUTs which are defective or have passed the test
2. Connect the new DUTs.
3. Press the **DUBPLICATE** button to copy the old PWT operation and paste a new operation with the same setting as the old measurement
4. Rename the replaced DUTs but keep the name of the DUTs which continue the power test.

**Extraction Tool**

The **EXTRACTION TOOL** collects the test results of a particular DUT which are stored in multiple operations, objects or even databases by searching for a string identifier stored in the property page **INFO** or the DUT name.

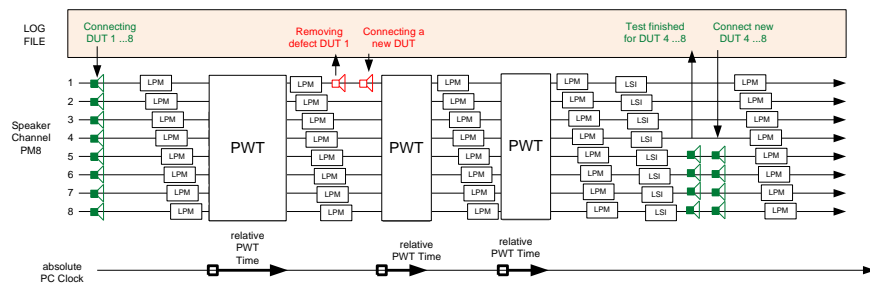
**Automation Interface**

The PWT software can be integrated into a customized application (C#, Labview, Microsoft EXCEL) via the automation interface.

**Log-File**

A summary of the most important information (name of DUTs, date, life time, failure, resonance frequency, ...) are stored in a separate file in csv-format. This file is a convenient interface to other software tools (Access, Excel, ...) to browse or summarize the results and to perform a query or statistical investigations.

## Limits

### Transducer

Parameter	Symbol	Min	Typ	Max	Unit
Voice coil resistance @ "Default" DA Speaker 1: 50 A <sub>p</sub> / 0 Ohm (15 A <sub>RMS</sub> ) Speaker 2: 0.5 A <sub>p</sub> / 0 Ohm (0.5 A <sub>RMS</sub> )	$R_e$ $R_e$	0.2 0.2	2 - 8 2 - 30	55 150	$\Omega$ $\Omega$
Voice coil resistance @ "High Sensitivity" DA Speaker 1: 25 A <sub>p</sub> / 0 Ohm (15 A <sub>RMS</sub> ) Speaker 2: 2 A <sub>p</sub> / 1 Ohm (1 A <sub>RMS</sub> )	$R_e$ $R_e$	0.2 0.2	2 - 16 8 - 100	45 600	$\Omega$ $\Omega$
Voice coil resistance @ "Very High S." DA Speaker 1: 2 A <sub>p</sub> / 1 Ohm (1 A <sub>RMS</sub> ) Speaker 2: 0.2 A <sub>p</sub> / 10 Ohm (0.2 A <sub>RMS</sub> )	$R_e$ $R_e$	0.2 0.2	8 - 100 100 - 1000	600 1000	$\Omega$ $\Omega$
Voice coil resistance @ "Default" PM8 Speaker 1 - 8: 50 A <sub>p</sub> / 0 Ohm (15 A <sub>RMS</sub> )	$R_e$	0.2	2 - 8	55	$\Omega$
Voice coil resistance @ "High Sens." PM8 Speaker 1 - 8: 2 A <sub>p</sub> / 1 Ohm (1 A <sub>RMS</sub> )	$R_e$	0.2	8 - 100	600	$\Omega$
Voice coil resistance @ "Very High S." PM8 Speaker 1 - 8: 0.2 A <sub>p</sub> / 10 Ohm (0.2 A <sub>RMS</sub> )	$R_e$	0.2	100 - 1000	1000	$\Omega$
Resonance frequency	$f_s$	15		500 (900)*	Hz
Total loss factor	$Q_t$	0.3		6	
Voice coil inductance	$L_e$	0.05		5	mH

\*The transducer identification of Microspeakers with a resonance frequency  $f_s$  above 500 Hz may be affected by creep and other nonlinearities not considered in the power test. It is recommended to use LPM and LSI Tweeter for measuring the linear and nonlinear parameters at high accuracy.

### External Excitation

Input Voltage for external excitation (peak)	$U_{max}$	-3.5		3.5	V
Input Impedance	$R_{in}$		10k		$\Omega$

### Power Amplifier

Maximal input level,				15	dBu
Input sensitivity at rated output power			0 (775)		dBu (mV)
High pass characteristic (damping at 4 Hz)				30	dB

### Automatic Pilot Tone Adjustment

Amplitude at loudspeaker terminals	$U_p$	0.010			V
Frequency (automatically selected according amplifier highpass characteristic)	$f_{pilot}$	2	2	8	Hz
Resolution of Impedance measurement			2		Hz
Amplitude Ratio (pilot tone referred to total voltage)	$U_{pilot}/U_{total}$	0.025		0.1	

Manual Pilot Tone Adjustment					
Amplitude at OUT1 or OUT2	$U_{\text{pilot}}$	0.001		1	V
Frequency of the pilot tone used in TEMPERATURE IDENTIFICATION MODE	$f_{\text{pilot}}$	2	2	18000	Hz
Frequency of the pilot tone used in TRANSDUCER IDENTIFICATION MODE	$f_{\text{pilot}}$	2	2	8	Hz
Allowed frequency mismatch between expected and asynchronous pilot	$\Delta f$	1	2	4	Hz
Resolution of impedance measurement at pilot tone		2		8	Hz
Time constant (integration in measurement)		0.2 <sup>1</sup>	3 <sup>2</sup>	45 <sup>3</sup>	s

<sup>1</sup> for manual setting (1 DUT, fast,  $f_{\text{pilot}} \geq 8\text{Hz}$ )

<sup>2</sup> for manual setting (1 DUT, fast,  $f_{\text{pilot}} = 2\text{Hz}$ )

<sup>3</sup> for manual setting (1 DUT, slow,  $f_{\text{pilot}} = 2\text{Hz}$ )

Input Parameters (Setup)					
Parameter	Symbol	Min	Typ	Max	Unit
<b>Stimulus</b>					
<b>Source</b>	<ul style="list-style-type: none"> <li>external (hardware controls external signal)</li> <li>internal (hardware controls internal generated signal)</li> <li>bypass (external signal directly supplied to DUT)</li> </ul>				
Starting value of voltage at terminals (rms)	$U_{\text{Start}}$	0.05		500	V
Amplitude amplification (stepping)	on / off				
Step size of amplitude amplification	$G_U$	0	1	6	dB
Maximal amplitude amplification (6 dB steps)	$G_{\text{max}}$	0		30	dB
<b>Noise Generator</b> (internal source)					
Spectral characteristic	pink, white or shaped noise according IEC 60268, EIA 426 B				
Lowpass cut-off frequency (- 3dB)	$f_{\text{low}}$	20		23040	Hz
Slope of the lowpass filter (order)	<i>slope</i>	6(1 <sup>st</sup> -), 12 (2 <sup>nd</sup> -), 24 (4 <sup>th</sup> -order)			dB/octave
Highpass cut-off frequency (- 3dB)	$f_{\text{high}}$	20		23040	Hz
Slope of the highpass filter (order)	<i>slope</i>	6(1 <sup>st</sup> -), 12 (2 <sup>nd</sup> -), 24 (4 <sup>th</sup> -order)			dB/octave
Crest factor	$C_r$	6		18	dB
<b>Sweep Generator</b> (internal source)					
Start frequency	$f_1$	1		20000	Hz
End frequency	$f_2$	1		20000	Hz
sweep time	$t$	1		100	s
Harmonic Distortion	THD		1		%
<b>Two-tone Generator</b> (internal source)					
Frequency of first tone	$f_1$	1		20000	Hz
Frequency of second tone	$f_2$	1		20000	Hz
Amplitude ratio between both tones	$U_2/U_1$	-100		0	dB
Harmonic Distortion	THD		1		%
<b>Cycles</b>					
ON-Interval <sup>2</sup>	$t_{\text{on}}$	1			s
Off-Interval <sup>2</sup>	$t_{\text{off}}$	2			s
Duration of total measurement	$t_{\text{tot}}$	0,1			h
Update cycle period	$T_{\text{upd}}$	1			s
Intermittent cycle mode	on / off				

<b>Methods</b>					
Modes	Temperature (PWT Pro and Lite) , TRANSDUCER IDENTIFICATION (PWT Pro only)				
Hardware settings (name, date, read and write function)	The Input Parameters (Setup) may be stored in the hardware unit (DA1)				
Number of DUTs	<i>DUT</i>	1		8	
Frequency of pilot tone	automatic adjustment (1...4 Hz) depending on high pass frequency of power amplifier used				
Speed of temperature measurement (depending on selected speed fast and slow)	$\tau$	0.375		6	s
<b>Material, Geometry Parameters</b>					
Effective area of the driver diaphragm.	$S_d$	0		10000	cm <sup>2</sup>
Material of voice coil	copper or aluminum				
<b>Failure</b> (permissible variation of $R_e$ )					
Min. resistance ref. to cold state	$R_{MIN}$	10		80	%
Max. resistance referred to cold state	$R_{Max}$	120		500	%
Max decrease voice coil temperature	$\Delta T_{TV}$	-273		-53	Kelvin
Max. increase voice coil temperature	$\Delta T_{TV}$	53		1053	Kelvin
<b>Import Parameters</b>					
Voice coil resistance at DC (required)	$R_e(T_v=T_a)$				$\Omega$
Force factor at rest position	$Bl(x=0)$				N/A
Moving mass	$M_{ms}$				g

Measurement Results			PWT- Lite	PWT-Intermittent (with PM8 only)	PWT-Pro
Large Parameters at the Rest Position ( $x=0$ ) <sup>1</sup>					
Electrical voice coil resistance	$R_e(t)$		✓	✓	✓
Electrical parameters $x \ll x_{max}$	$L_e, L_2, R_2, C_{mes}, L_{ces}, R_{es}$				✓
Mechanical parameters $x \ll x_{max}$ <sup>1</sup>	$M_{ms}, R_{ms}, C_{ms}(t), BI$				✓
Derived parameters $x \ll x_{max}$	$Q_{eps}, Q_{tp}, Q_{ms}, T_v, Q_{es}(t), Q_t, f_s(t)$				✓
Small Signal Parameters <sup>3</sup>					
Electrical voice coil resistance	$R_e(t)$			✓	✓
Electrical parameters	$L_e, L_2, R_2, C_{mes}, L_{ces}, R_{es}$			✓	✓
Mechanical parameters	$M_{ms}, R_{ms}, C_{ms}(t), BI$			✓	✓
Derived parameters	$Q_{eps}, Q_{tp}, Q_{ms}, T_v, Q_{es}(t), Q_t, f_s(t)$			✓	✓
Transducer States					
Electrical signals	$U_{rms}(t), I_{rms}(t), U_{peak}(t), I_{peak}(t), P(t), pdf(U)$		✓	✓	✓
Displacement (predicted by using imported BI( $x=0$ )) <sup>1</sup>	$x_{peak}(t), x_{bottom}(t), x_{dc}(t), x_{max}(t)$				✓
Displacement (measured by using a Laser) <sup>2,4</sup>	$x_{peak}(t), x_{bottom}(t), x_{dc}(t)$		✓		✓
Analyzed distortion components	$dc(t), d_L(t), d_{BI}(t)$				✓
Temperature (regular and fast sampling) <sup>2</sup>	$\Delta T_v(t)$		✓	✓	✓
Nonlinear Parameters					
Voice coil Inductance	$L_e(x), L_e(x_{rel}),$				✓
Force factor (effective BI-product) <sup>1</sup>	$BI(x), BI(x_{rel})/BI(0),$				✓
Suspension characteristic <sup>1</sup>	$K_{ms}(x), K_{ms}(x_{rel})/K_{ms}(0)$				✓

<sup>1</sup> absolute identification of the mechanical parameters and states requires import of  $BI(x=0)$  and/or  $M_{ms}$

<sup>2</sup> for 1 DUT only

<sup>3</sup> realized by LPM

<sup>4</sup> realized with DA2 only



## Example: Analysis of the Destruction Process

### History

The Power Test monitors the parameter and state variables of each DUT and stores this data in the history buffer automatically. Connecting a PC to the measurement hardware the user may view the test conditions (supplied voltage and power) and the behavior of the DUT during the whole measurement. If a driver is damaged during the test, a death report shows the period just before destruction in greater details. It is most important not only to find all of the defects such as

- Mechanical suspension damaged due to high displacement
- Voice coil damaged due to high displacement
- Voice coil damaged due to thermal overload

but also the sequence of the destructive events and the initial failure.

### Voice Coil Resistance

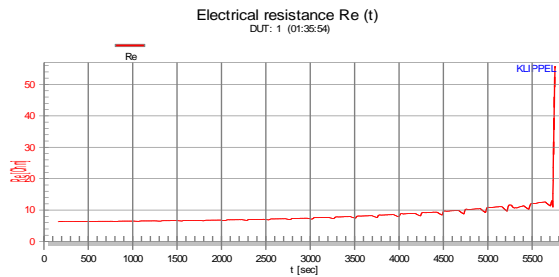

The electrical resistance  $R_e$  of the voice coil increases with the instantaneous voice coil temperature. A sudden increase indicates a loose connection or a broken coil. A sudden decrease is caused by a shortcut of the windings in the gap.

### Suspension

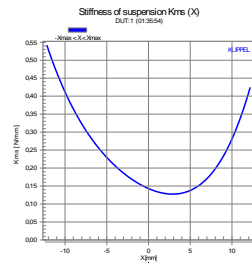

The properties of the mechanical suspension are represented by the nonlinear stiffness  $K_{ms}(x)$  versus displacement  $x$  and the stiffness  $K_{ms}(t, x=0)$  at the rest position versus measurement time.

A high increase of the stiffness at maximal displacement  $x=x_{max}$  in the nonlinear characteristic indicates high mechanical load which may cause a destruction of the suspension.

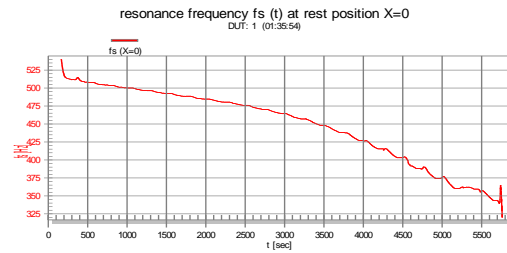

Reversible and nonreversible processes such as creep or ageing cause a decrease of the stiffness and resonance frequency during the measurement time which is normal for most drivers (figure below). A sudden decrease of  $f_s(x=0)$  indicates a broken suspension or a lost joint.

### Temperature, Input Power

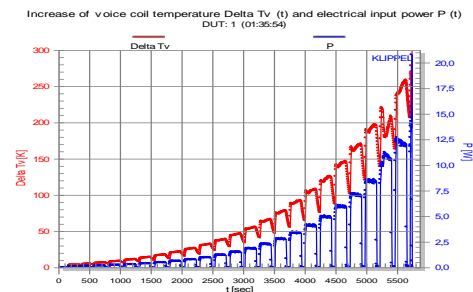

The voice coil temperature (upper curve) is closely related to the real input power (lower curve) supplied to the transducer. Both state variables plotted versus measurement time give important information for defining admissible maximal input power.

### Displacement

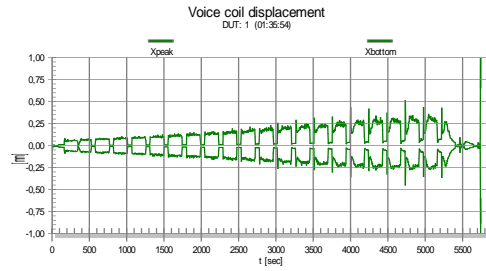

The instantaneous displacement is the most important mechanical state variable. The maximal displacement  $X_{max}$  determines the maximal acoustical output possible at low frequencies. If the driver is damaged during Power Test the peak and bottom value of the displacement may show the mechanical condition.

### Patents

Germany	102007005070, 1020120202717, 43340407, P4332804.0
USA	8,078,433, 14/436,222, 5815585
China	ZL200810092055.4, 201380054458.9
Japan	5364271
Europe	13786635.6
Taiwan	102137485
India	844/MUMNP/2015

Find explanations for symbols at <http://www.klippel.de/know-how/literature.html>



Document Revision 2.1

updated 30 March 2017

Klippel GmbH  
Mendelssohnallee 30  
01309 Dresden, Germany

[www.klippel.de](http://www.klippel.de)  
[info@klippel.de](mailto:info@klippel.de)

TEL: +49-351-50 19 39 0  
FAX: +49-351-50 19 39 10